

# Uni Gliding

Volume 18, Issue 6

November 1993

An official publication of The Adelaide University Gliding Club Inc.

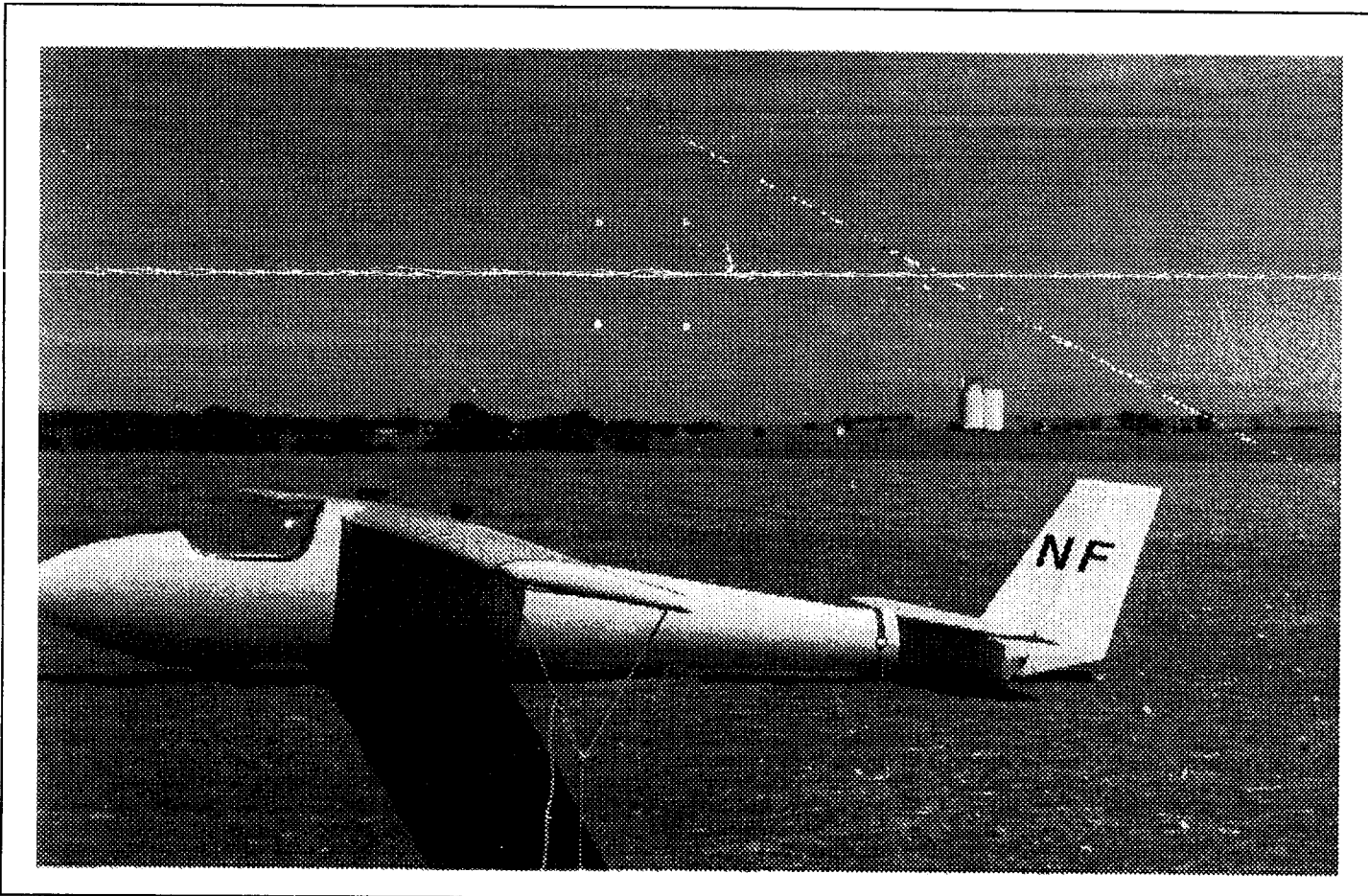

## *Wheelchair Basketball December 1st.*

To celebrate his return to the land of the upright Scott Battersby has organized a game of wheelchair basketball. This will be held at the Urrbrae Agricultural College Gym at 7:30 pm. on December 1st. The College is out at the corner of Cross and Fullarton Roads. Give Scott a call to let him know if you can come: Tel# 382 3213(hm) or 303 3157(wk).

## *Special General meeting*

(El Dictatore will be administered the Coup de Grace)

Translation: Our president is being sent to Melbourne by his work for a while and his successor must be chosen. This will be done at this meeting which is to take place at Peter Cassidy's residence ( 13th December, 2a Olinda Ave. Windsor Gardens at 7:30 pm.)

## *Pool Party December 13th.*

Following the election of our new president a party will follow. This is to continue straight on from the above meeting or 8:00 pm. whichever comes first. So bring along yourselves, your togs and your favourite poison.

## Minutes Summary of Executive Meeting, 15/9/93

The executive meetings are held on the third Wednesday of every month, and are meetings where the club's members discuss and decide on matters pertaining to the club's operation. Everyone is welcome. See below for the location of the next meeting.

In an effort to let the "masses" know what their club is doing, I've finally got around to giving a summary of the last minutes (Jeff took a month to write them & I took a month to print them - sorry Ed.); hopefully, study allowing, I can give a summary of each meeting. For those who are extremely keen, a copy of the minutes in full can be obtained off of me.

It is noted that many items that are discussed at an executive meeting are generally not completed by the next meeting, one month later. For this month only, I will present a rundown of the club's current issues. However, in future I will only mentioned new events that arise during the executive meetings:

Jeff Brenton, Secretary.

### Business Arising (from previous minutes):

Events that were discussed at the August executive meeting, and completed since that meeting, include the following:

- The faulty 'automatic' brakes on the winch's cable drums have been fixed;
- The cable head pulleys on the winch that were excessively grooved have been built up, and are now back on the winch;
- The 3000 flight hour inspection (a very thorough inspection) of the club's fibreglass high performance single seater, the Libelle, has finally been completed;
- A new harness for another of the club's single seater, the Super Arrow, has been ordered;
- The materials for the winch truck's sheared chassis have been purchased, with the repair work just about to start.

### Correspondence

The following relevant mail was received:

- A memo from the Adelaide University Sports Association notifying the club of Gary Hollands's success in being awarded a Club Letter for his achievements in the recent State Contests;
- A letter from the Barossa Valley Gliding Club declining our invitation for them to come and fly with us on the 4<sup>th</sup> and 5<sup>th</sup> of September. However, they expressed interest in flying at a latter date;
- A poster from Bordertown-Keith Gliding Club advertising the State Contest Regatta they are holding in late January.

### Treasurer's Report (Stephen Were)

Currently, the club's general finances stands at about \$3000. Also we need to spend \$6000 on capital items before early November in order to receive the \$4000 capital grant from the Sports Association. (For those who don't know, the club, being affiliated with the AU Sports Assoc. (AUSA), asks for a grant each year to spend on capital works. This year the AUSA has granted us \$4000 if we present them with \$6000 worth of receipts spent on capital works; this is one of the reasons as to why our club offers the cheapest flying rates in Australia.)

### Social Convenor's Report (Scott Battersby)

*Jurassic Park* was a *dinosaur* (sorry) of an event for all those who attended. Up and coming events include:

- Another Go-Karting adventure on Monday 18<sup>th</sup> October. See me (ph: 314601) for deposit ASAP (WARNING: bring protective gear if racing with Redmond Quinn);
- Annual Club dinner Friday 22<sup>nd</sup> October, at Montazumas(?). Contact Jeff Brenton (ph: 434518) ASAP for bookings.

### General Business

The following matters, some of which arose during previous executive meetings, are currently being attended to by the club:

- Safety features are to be placed on the winch to protect the driver from cable shrapnel that results from cable breaks;
- A First Aid kit is to be made up and placed on the winch;
- The winch truck engine (the engine that drives the truck) is misbehaving. As a step towards solving this problem, comparative quotes will be obtained on reconditioning the existing engine, versus purchasing a brand new one;
- Airworthiness:
  - Two of the club's aircraft are in for inspections at our West Beach workshed. The two seater Bergfalk is in for it's annual 'form 2' inspection (week begin. 4<sup>th</sup> Oct.), whilst the single seater wooded Arrow is in for it's 30 yearly inspection (week begin. 27<sup>th</sup> Sept.). All hands on deck!
  - A new main wheel for the Bocian is to be purchased and fitted;
  - Upgrading work on the trailers of the Bergfalk, Super Arrow and Arrow is currently being undertaken;
- Lights and power points are to be fitted in the new section of the West Beach workshed;
- The grass outside of the main door of this shed is to be dug up and replaced with dolomite;
- Security screens for the clubhouse's windows and door are to be fitted;
- Tiles for the recently constructed second clubhouse bathroom are to be purchased before the State Competition the club is hosting in early December;
- The two paths leading to the clubhouse are to be paved in an effort to halt the entry of dirt into the clubhouse. Landscape drawings should be completed by mid-December;
- More trees need to be planted around the clubhouse, and fences erected around the existing ones to prevent the sheep from having a meal;
- Some bitumen foam has been purchased, and needs to be placed into the gap in the northern clubhouse wall;
- More club t-shirts and windcheaters are being printed;
- The cut off date for capital grant expenditure of \$6000 is fast approaching. The primary item to be bought is a truck for the new winch (that is to be constructed over the next year). Failing this though a number of other capital items were discussed:
  - two radios, an icom for the Arrow, and another for the Super Arrow;
  - a barograph;
  - a cheap printer (<\$250) for the clubhouse, to unload the barograph data;
  - a cheap fax machine for the clubhouse, to obtain cross country meteorology forecasting;
  - variometers, with McCready rings (if applicable) for all aircraft;
  - A photo board of the club's executive members and instructors is to be made up and placed in the clubhouse;

- An advertisement is being placed in the Lochiel pub to let the locals know that we exist;
- A signpost on the Snowtown road is to be erected, so as to enable the field to be more easily found by newcomers;
- In an effort to counter the general decline in active gliding membership present throughout most of the gliding movement, a new non-executive position was made: *Public Relations Officer*. This person's primary role is to oversee the club's promotional activities. See Jeff Brenton if interested;
- Before the summer heat arrives, a new pic-cart (a shelter on wheels) will hopefully have been obtained. Some general arrangement drawings should be done by mid-December.
- The ruts at the cross strips are causing a concern for the winch. They need to be levelled with a shovel, if possible;
- The club's newsletter should be sent to the following groups: all SA clubs, *Australian Gliding*, and Queensland University Gliding Club (as they are a newly formed club).

**Next Meeting:** Wed. 20<sup>th</sup> October, 7:30pm, Jeff Brenton's residence, 2 Elba Ave. Lockleys.

## The S.A. State Gliding Competition

A leg of the State comps will be held at AUGC this year. The State competition has returned to a regatta based system where pilots travel to differing clubs and try a wide range of locations. So there should be some new faces and some new planes to have a look at.

If at all interested in what happens at a State Comps (apart from Bradley winning) drop in and have a look.

For those of you who can help please contact Catherine Conway or one of the other Instructors.

The date is the Weekend 11/12<sup>th</sup> of December.

And yet another classified Ad. from these landlords (and I still haven't got my bottle of port...Ed)

### **A 2 Bedroom Unit**

**44/1 Maria St.**

**Melrose Park**

**\$100/pw**

Call Gary Hollands Tel: # 271 2020

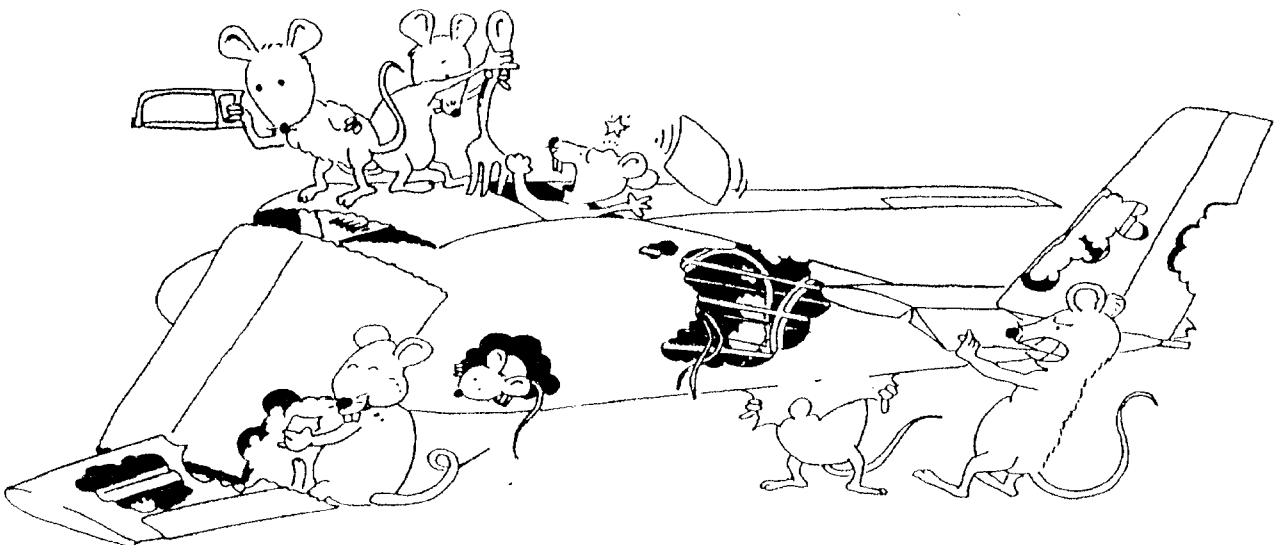

# AUGC 93/94 Christmas Competition

During the week after Christmas AUGC will be holding a competition aimed at stimulating cross-country flying and forming an introduction to competition flying. All pilots from our club from pre-solo to competition level are eligible to enter. Although this is a low-key competition within our club all rules must be followed to be eligible for a placing. A small daily entry fee will cover running costs and the trophies for the daily and overall winners.

## Calendar:

Mon 27/12	Boxing Day	Comp Day 1
Tues 28/12	Proclamation Day	Comp Day 2
Wed 29/12		Comp Day 3
Thurs 30/12		Comp Day 4
Fri 31/12	New Years Eve	Comp Day 5
Sat 1/1	New Years Day	Comp Day 6
Sun 2/1		Comp Day 7
Mon 3/1	Public Holiday	Normal flying

Presentation to the overall winner and a lamb-on-the-spit dinner will be on the Sunday evening.

## Rules:

1. Only current members of AUGC are eligible.
2. All types of gliders are eligible and fly in the same class. No water ballast is allowed.
3. Tasking will be pilot optioned distance tasking (PODT). Pilots should aim to fly the longest possible distance, choosing suitable turn points, and return to the airfield (no pre-declaration of tasks is required).
4. There shall be a maximum of two turn points.
5. Turn points may be any readily recognizable feature on a WAC.
6. All turn points must be photographed according to the rules specified in the sporting code.
7. Turn point photos are mandatory and all films must be 35mm colour supplied by the competitor. Each competitor may use the same film for the entire competition. Films will be developed after the competition at the competition directors discretion.
8. All gliders start together and must photograph the start signal which will be set 10 minutes after the launch of the last glider (re-lights don't count). The time taken for the task is unimportant.

## Scoring:

The base score is the distance achieved, multiplied by the handicap of the glider flown. Outlanding carries a 20% penalty. The winner for each day is awarded 1000 points and other placings awarded their base score divided by the winners base score and multiplied by 1000. Both pilots in a twin seater score the same points. A provisional winner will be awarded for each day subject to film verification. Overall winner and placings will be based on the best two scores for each pilot.

## Handicaps:

Pik 20B	0.94	
Std Libelle	1.11	
Club Libelle	1.15	
Boomerang	1.29	Note: These handicaps are derived from the decentralised competition
Super Arrow	1.30	handicaps modified to favour the lower performance gliders.
Bergfalke	1.33	
Bocian	1.44	
Arrow	1.44	

## Further Information:

Booking of aircraft and entry fee will be decided closer to the competition. For more information contact Peter Temple (competition director).

# *Curious about what goes on inside?*

WELL THEN COME ALONG TO THE TALK ON AIRCRAFT STRUCTURES

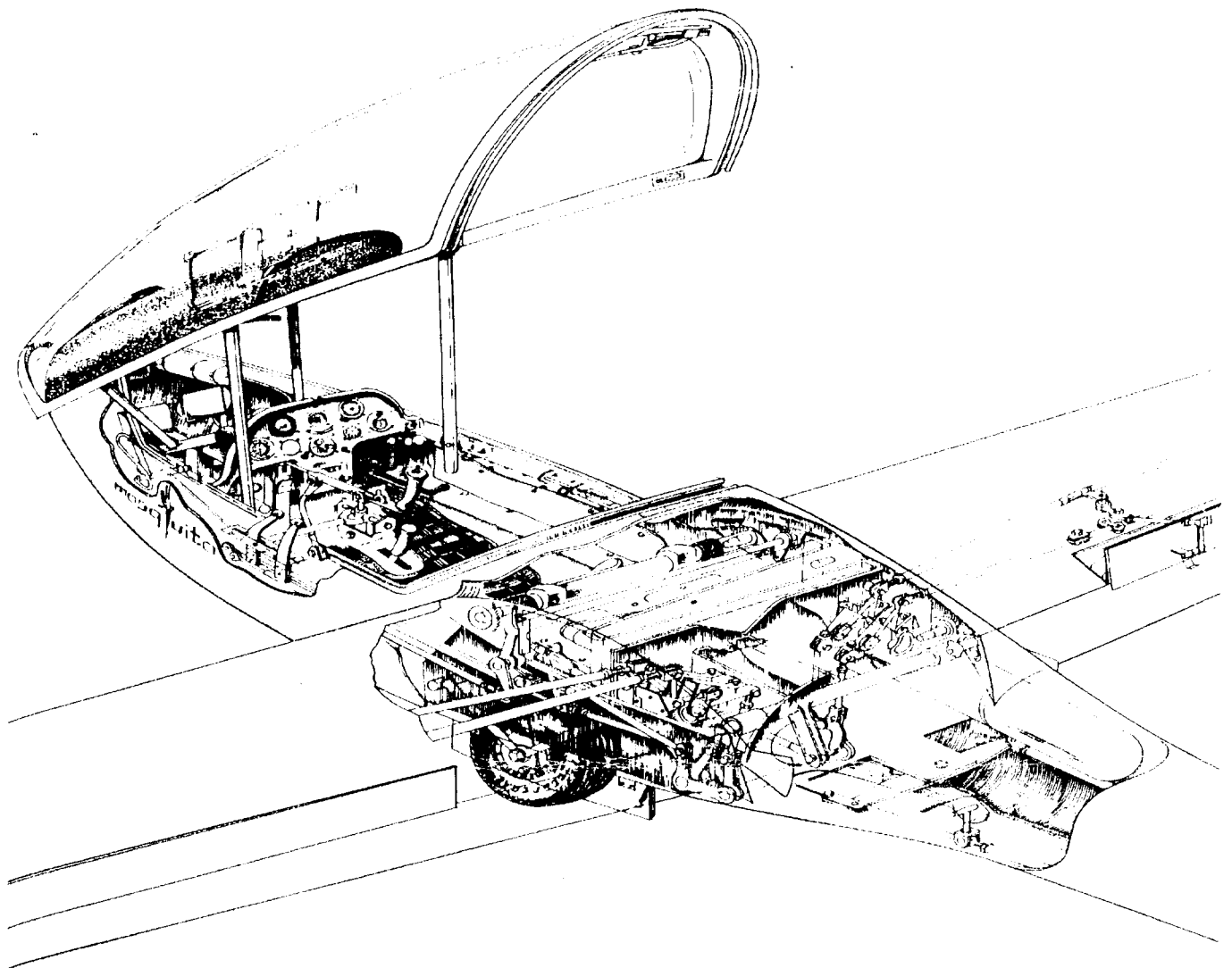

The talk will be held at West Beach where the club currently has lots of good bits to poke around into. YES that's right you don't just have to sit down and listen.

**Place:** 1 Foreman St. West Beach. **Time:** 7:30 pm on Wednesday December 8th.